

# MODEL 345EA10 10-1/2" REEL EXTENSION ADAPTER FOR THE AKAI MODEL 345 TAPE RECORDER (DECK

## 1. COMPONENT PARTS : (Refer to Fig. 1.)

- |                                   |                                    |
|-----------------------------------|------------------------------------|
| 1) 10-1/2" REEL ADAPTER ARM. X 2. | 5) 7" REEL TABLE, WITH GROOVE REEL |
| 2) INCLUDED IN ITEM 1.            | TABLE. FOR THE RTMA STANDARD. 2.   |
| 3) ADAPTER REEL SHAFT.            | 6) NARTB TYPE REEL ADAPTER. 2.     |
| (INCLUDED IN ITEM 1.)             | 7) REEL RETAINER. 2.               |
| 4) BELT TENSION ADJUSTOR.         | 8) REEL DRIVING BELT. 2.           |
| (INCLUDED IN ITEM 1.)             | 9) BELT GUIDE ROLLER. 2.           |
|                                   | (INCLUDED IN ITEM 1.)              |

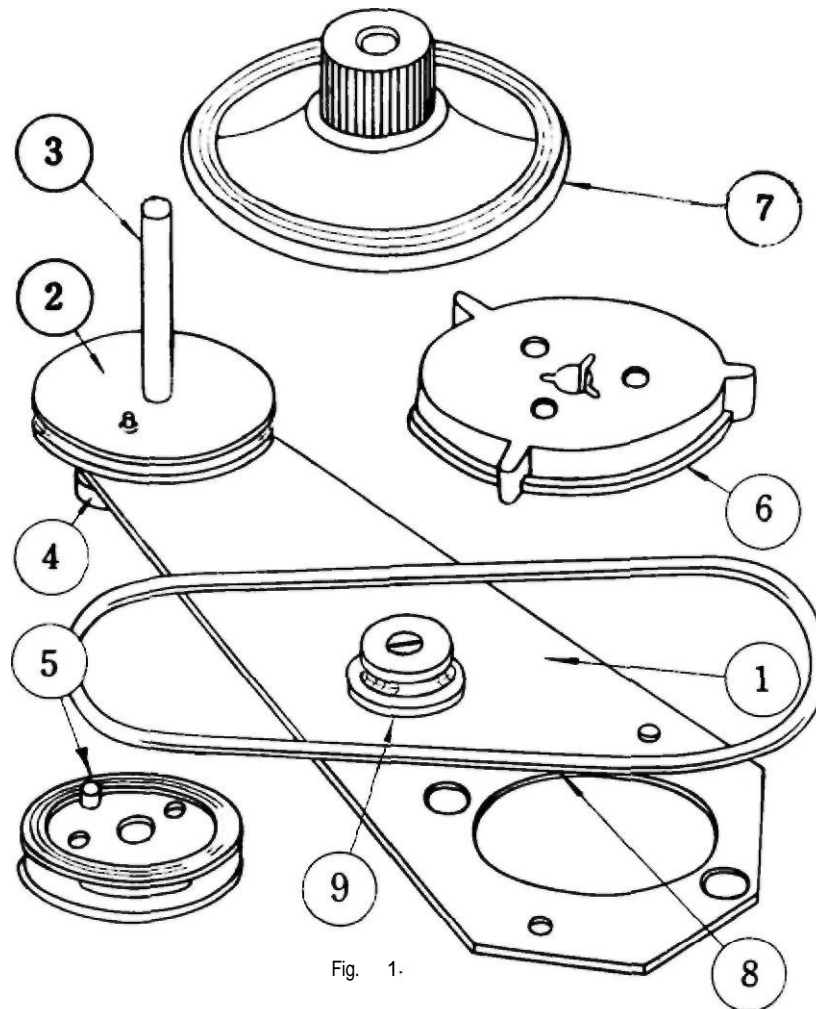

Fig. 1.

**2. Preparation:** (Refer to Fig. 2.)

Remove mounting screws (12) on the right and left reel tables using a phillips-type screw driver.

These screws are set in the screw holes (15) in the pulley. Remove right and left reel tables (13) by carefully raising up along with the shaft.

Remove screws (11) on the right and left reel table rings. These screws are set in screw holes (16) of the recorder's top panel.

Remove these rings (14) from the right and left reel tables. Remove motor set screws (17) which shall be used to set the 10 1/2" Reel Adapter Arm in position.

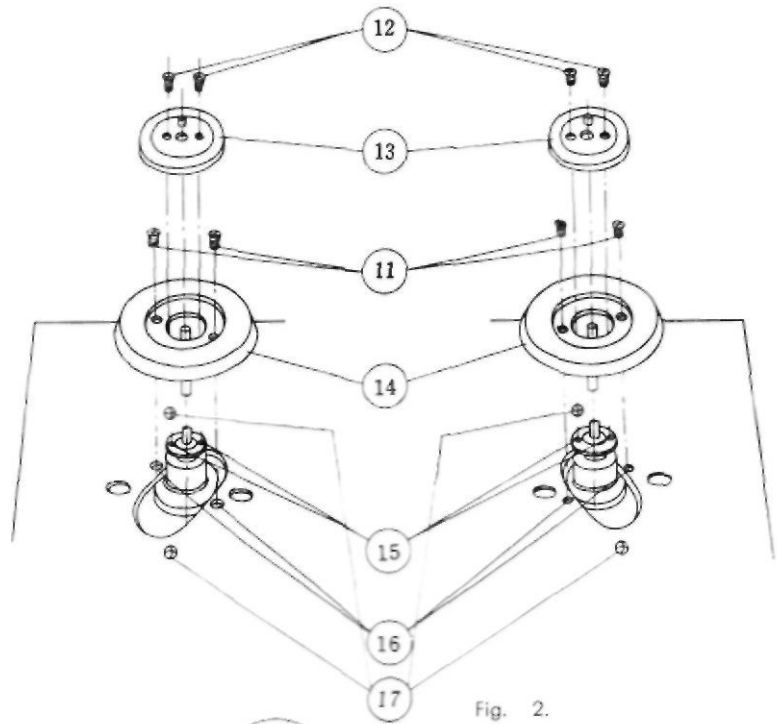

Fig. 2.

**3. Installation:** Refer to Fig. 3.)

Set the Reel Adapter Arm in Holes (17) shown in Fig.2 using Motor set screws (17). By using reel table set screws (12) previously removed in Fig. 2, 7" reel table with groove for Belt (5) mentioned in Fig. 1 of "Accessories" shall be put in holes (15) of Fig. 2 and be tightened.

Set the Belt (8) on Belt Groove and 7" Reel Table on the RTMA type reel table in Fig. 3.

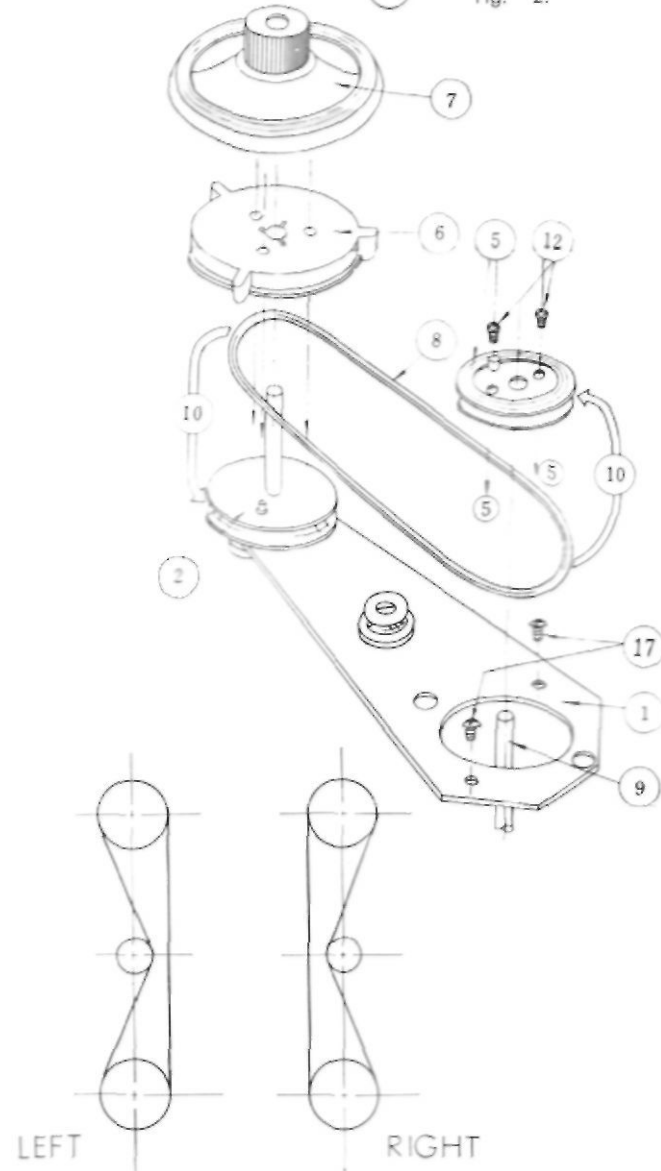

Fig. 3.

#### 4. RTMA TYPE and NARTB Reels:

There are 2 different types of 10-1/2" Reels used in the current tape recording industry.

##### 1. RTMA Type Reel.

RTMA Type Reel is similar, in shape, to those Standard 3", 5", or 7" reels as shown in Fig. 4.

This type of reel can be used on Reel Table (2) of Fig. 3.

##### 2. NARTB TYPE REEL

This type of reel is shaped in its core as shown in Figure 5, and is mostly made of metal. This reel is to be used by putting the NARTB type reel adapter (6) in Fig. 3 on the RTMA type reel table (2) of the same figure.

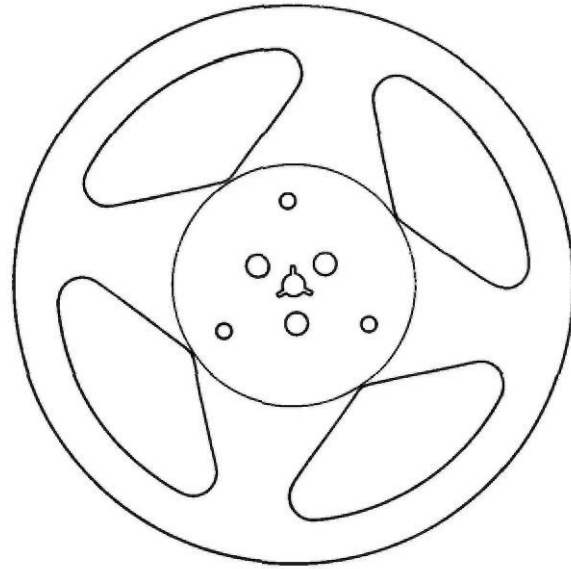

Fig. 4.

#### 5. OPERATION:

When 10-1/2" reel is used, it is important to hold it on the reel shaft as tight as possible using the reel retainer (7) shown in Fig. 3. Put the reel retainer by slightly rotating it in either direction to hold the 10-1/2" reel tight in position.

The 10-1/2" Reel Adapter has now been perfectly set and is ready to operate.

Conventional smaller reels of 7", 5" or 3" in diameter can also be used without removing 10-1/2" Reel adapter. In this case, place the reel on the reel table (5).

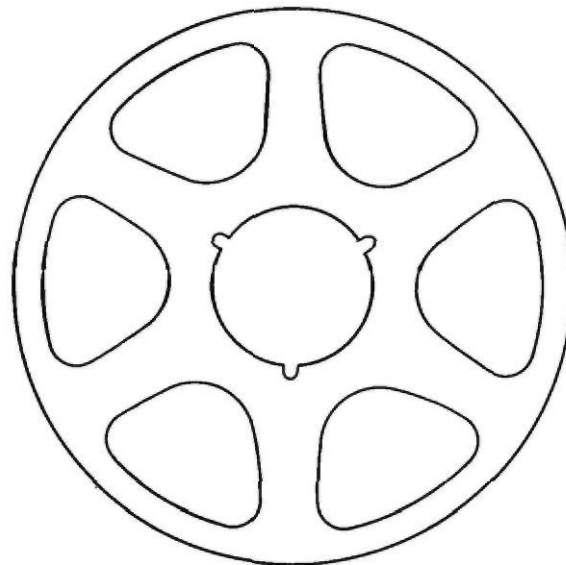

Fig. 5

6. ADJUSTMENT: (Refer to Fig. 6.)

Although the 10-1/2" reel adaptor has been factory adjusted, the normal function of the adapter mechanism will be affected if the belt tension is too tight or loose.

In such case adjustment shall be made by loosening the Belt Adjustment Screw on the tension adjustor to be found on the rear side of the adapter reel shaft.

If the belt tension adjustor is moved in the direction of the arrow (B), the distance is extended to give greater tension on the belt. If it is moved in the direction of the arrow (C) the distance is decreased and tension on the belt will be decreased.

After adjustment has been completed, tighten the belt adjustment Screw (D).

Caution : Do not attempt to use this extension reel adaptor when the model 345 is to be operated at the highest tape speed of 15 i. p. s.

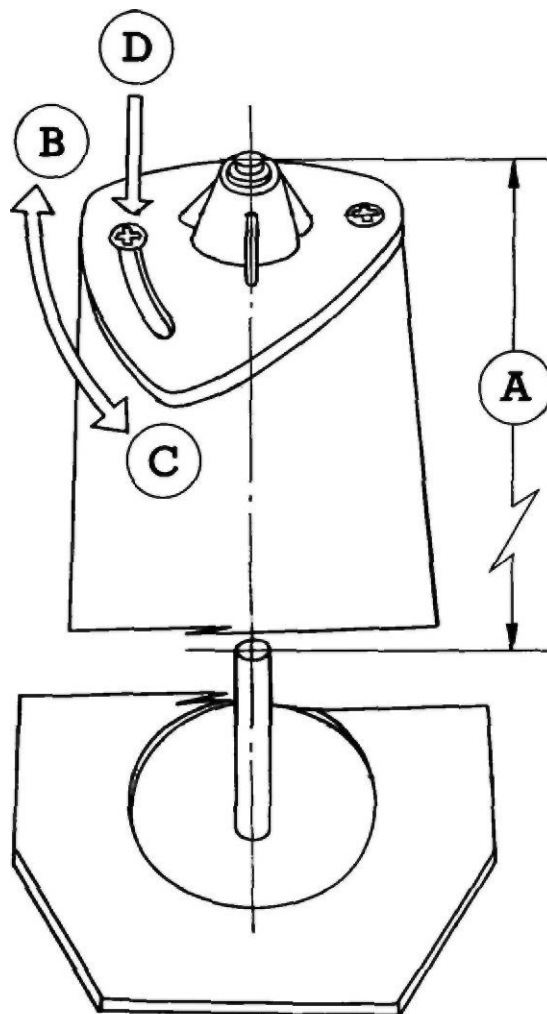

Fig. 6.